

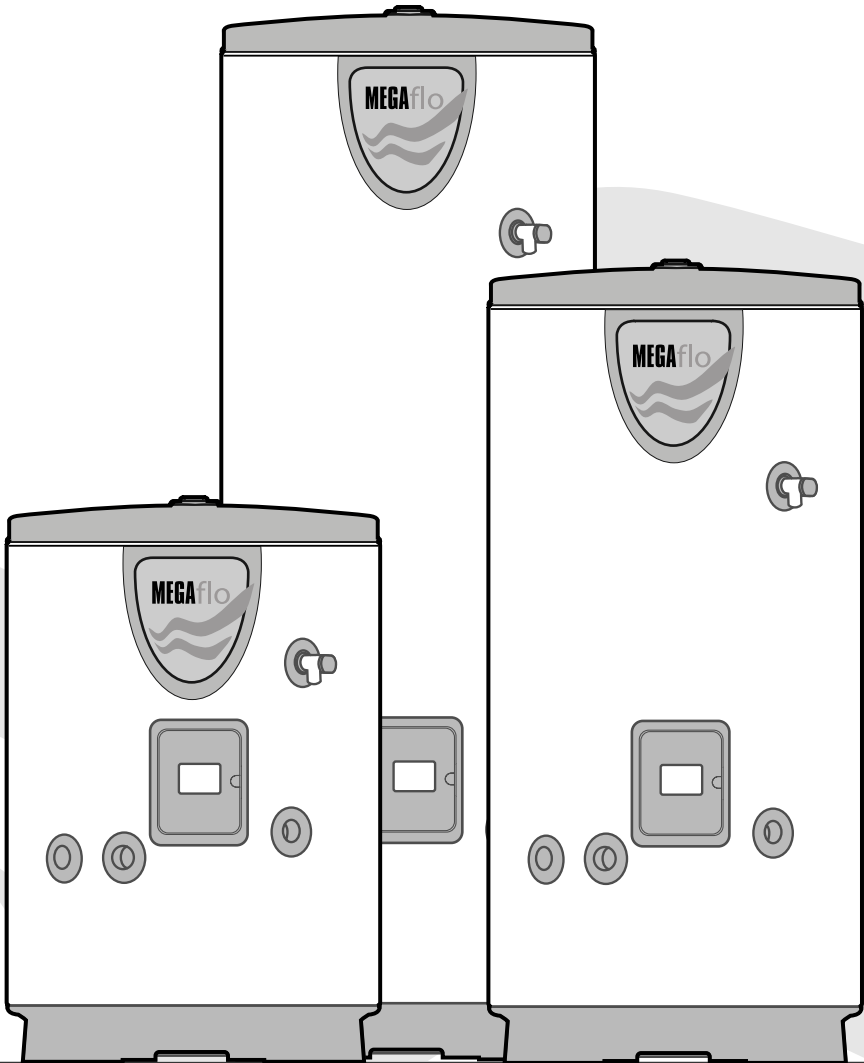

# MEGAflo<sup>®</sup>

## Installation Manual



Fitting and using the MEGAflo unvented mains  
pressure water heater

**HEATRAE SADIA**

The quality name in water heating

36005823 issue 5

# Contents

SECTION		PAGE
1	INTRODUCTION .....	3
2	GENERAL REQUIREMENTS .....	4
3	INSTALLATION - GENERAL .....	7
4	INSTALLATION - DIRECT UNITS .....	16
5	INSTALLATION - INDIRECT UNITS .....	18
6	COMMISSIONING .....	23
7	USER INSTRUCTIONS .....	25
8	MAINTENANCE .....	27
9	FAULT FINDING & SERVICING .....	29
10	DIMENSIONS & SPECIFICATIONS .....	32
11	GUARANTEE .....	35
12	CONTACTS .....	36

**Please read and understand these instructions before starting work.  
Please leave this leaflet with the user following installation**

## Introduction

Congratulations on your purchase of a Heatrae Sadia Megaflo High Efficiency unvented water heater. The Megaflo is manufactured in the UK from top quality materials and meets all the latest relevant safety and constructional standards. The high grade Duplex stainless steel cylinder offers exceptional strength and corrosion resistance which is backed by a 25 year guarantee. Its performance and insulation levels exceed the latest requirements of Building Regulation Part L.

The Megaflo unvented water heater can be fed directly from the cold water mains supply to the property without the need for separate feed cisterns or vent pipes. It is supplied complete with all its necessary inlet and safety controls, electric immersion heater(s) and, for indirect units, a cylinder thermostat, thermal cut-out, 2-port motorised valve and wiring centre.

Generally its pressure and flowrate performance will far exceed that from a comparable vented system, thermal store, multipoint instantaneous gas heater or combination boiler.

The Megaflo requires no separate expansion vessel as any expanded water is accommodated within an internal air volume.

**Figure 1 - Schematic installation details**

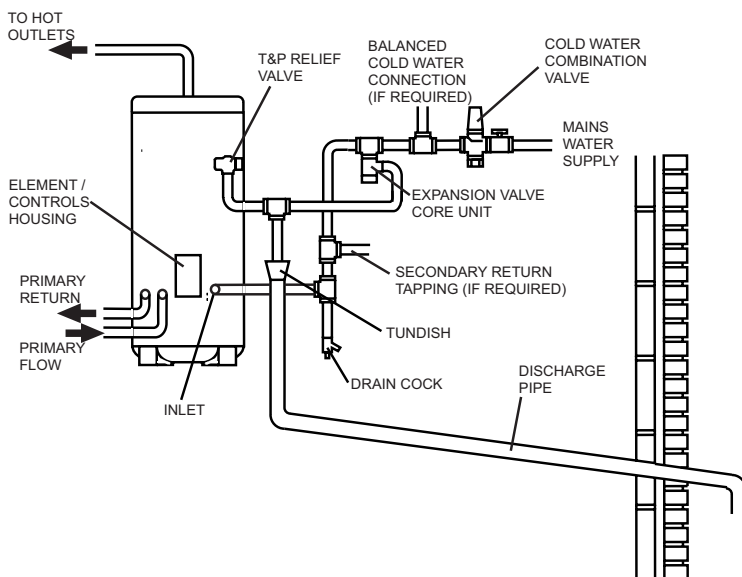

# General Requirements

**IMPORTANT : PLEASE READ AND UNDERSTAND THESE INSTRUCTIONS BEFORE INSTALLING THE MEGAFLO WATER HEATER. INCORRECT INSTALLATION MAY INVALIDATE GUARANTEE.**

**THIS APPLIANCE IS NOT INTENDED FOR USE BY PERSONS (INCLUDING CHILDREN) WITH REDUCED PHYSICAL, SENSORY OR MENTAL CAPABILITIES, OR LACK OF KNOWLEDGE AND EXPERIENCE, UNLESS THEY HAVE BEEN GIVEN SUPERVISION OR INSTRUCTION CONCERNING THE USE OF THE APPLIANCE BY A PERSON RESPONSIBLE FOR THEIR SAFETY.**

**THE MEGAFLO MUST BE INSTALLED (SECTIONS 2 - 5), COMMISSIONED (SECTION 6) AND MAINTAINED (SECTIONS 8 - 10) BY A COMPETENT INSTALLER IN ACCORDANCE WITH BUILDING REGULATION G3 (ENGLAND AND WALES), TECHNICAL STANDARD P3 (SCOTLAND) OR BUILDING REGULATION P5 (NORTHERN IRELAND) AND THE WATER FITTING REGULATIONS (ENGLAND AND WALES) OR WATER BYELAWS (SCOTLAND). FOLLOWING INSTALLATION AND COMMISSIONING, THE OPERATION OF THE HEATER SHOULD BE EXPLAINED TO THE USER (SECTION 7) AND THESE INSTRUCTIONS LEFT WITH THEM FOR FUTURE REFERENCE.**

## 2.1 COMPONENT CHECK LIST

Before commencing installation check that all the components for your Megaflo unit are contained in the package. The following components are supplied as standard with your Megaflo unit :

- Factory fitted immersion heater (s) and thermal controls
- Cold Water Combination Valve (comprises Isolating Valve, Pressure Reducing Valve, Strainer, and Check Valve)
- Expansion Core Unit (comprises Check Valve and Expansion Valve)
- Factory fitted Temperature/Pressure Relief Valve (set at 90°C/1 Mpa (10bar))
- Tundish (included in Cold Water Combination Valve pack)
- Factory fitted Indirect Thermostat and Thermal Cut-out (CL units only)
- T&P Relief Valve Insulation Set
- Drain Valve
- Wiring Centre (CL units only)
- 2-Port Motorised Valve (CL units only)
- Lifting handle

## 2.2 SITING THE MEGAFLO (see Figure 1)

The Megaflo unit must be vertically floor mounted. It can be placed anywhere convenient provided the discharge pipe(s) from its safety valves can be correctly installed. Areas that are subject to freezing must be avoided. Ensure that the floor is of sufficient strength to support the "full" weight of the unit (refer to Tables 4 and 5 on page 33 for unit weights). Pipe runs should be kept as short as possible for maximum economy. Access to associated controls, immersion heaters and indirect

controls should be possible for servicing and maintenance of the system (Note: indirect controls housing hinges open to the left hand side).

Please do not install valves or pipework (except discharge pipe) within 50mm (2") of the T&P relief valve to allow your insulation set to be fitted. The insulation set is important to ensure heat and energy conservation. See section 3.8 for more information.

To aid installation the Megaflo is provided with lifting points located in the base moulding and a lifting handle. The lifting handle should be fully threaded onto the outlet boss before use. Once the Megaflo is suitably positioned the lifting handle should be removed to allow connection of the outlet pipework. The weights of the units are noted on the tables on page 33.

### 2.3 WATER SUPPLY

Bear in mind that the mains water supply to the property will be supplying both the hot and cold water requirements simultaneously. **It is recommended that the maximum water demand be assessed and the water supply checked to ensure this demand can be met.**

**NOTE: A high mains water pressure will not always guarantee high flow rates.**

Wherever possible the main supply pipe should be in 22mm. The minimum mains water supply requirements should be 0.15 MPa (1.5 bar) working pressure and 20 litres per minute flowrate. At these values outlet flowrates may be poor if several outlets are used simultaneously, the higher the available pressure and flowrate the better the system performance will be.

The Megaflo has an operating pressure of 3 bar which is controlled by the Cold Water Combination Valve. The Cold Water Combination Valve can be connected to a maximum mains supply pressure of 1.6 MPa (16 bar). The water supply must be of wholesome water quality (Fluid Category 1 as defined by the Water Supply Regulations 1999).

### 2.4 OUTLET/TERMINAL FITTINGS (TAPS, ETC.)

The Megaflo can be used in conjunction with most types of terminal fittings. It is advantageous in many mixer showers to have balanced hot and cold water supplies, in these instances the balanced cold water supply should be teed off the supply to the Megaflo immediately after the Cold Water Combination Valve (see Figures 4 and 5). Branches to cold drinking outlets should be taken before the valve.

Outlets situated higher than the Megaflo unit will give outlet pressures lower than that at the heater, a 10m height difference will result in a 0.1 Mpa (1 bar) pressure reduction at the outlet fitting.

**NOTE: Accessories should have a rated operating pressure of at least 0.8 MPa (8 bar).**

## 2.5 LIMITATIONS

The Megaflo unvented water heater should not be used in any of the following instances:

- Solid fuel boilers or any other boiler in which the energy input is not under effective thermostatic control unless additional and appropriate safety measures are installed.
- Gravity circulation primaries.
- Steam heating plant unless additional and appropriate safety devices are installed.
- Ascending spray type bidets or any other Class 5 back syphonage risk requiring that a Type AA, AB, AD or AG air gap be employed.
- Water supplies that have either inadequate pressure or where the supply may be intermittent.
- Situations where it is not possible to safely pipe away any discharge from the safety valves.
- Areas where the water consistently contains a high proportion of solids, eg. suspended matter that could block the strainer, unless adequate filtration can be ensured.
- The installation must be carried out in accordance with the relevant requirements of:
  - The appropriate Building Regulations: either The Building Regulations (England), The Building Regulations (Scotland) or Building Regulations (Northern Ireland).
  - The Water Fittings Regulations (England and Wales) or Water Byelaws (Scotland).

# Installation - General

## 3.1 PIPE FITTINGS

All pipe connections to the Megaflo are made via 22mm compression fittings directly to the unit (nuts and olives supplied). The fittings are also threaded 3/4" BSP male parallel should threaded pipe connections be required.

## 3.2 COLD WATER SUPPLY

A 22mm cold water supply is recommended, however, if a 15mm (1/2") supply exists which provides sufficient flow (see section 2.3) this may be used. More flow noise may be experienced from small bore pipes due to the increased water velocity through them.

The Cold Water Combination Valve supplied with the Megaflo incorporates a full flow isolating valve which will enable the Megaflo to be isolated from the mains supply for maintenance or servicing. To close the valve the black handle should be turned so that it lies at 90° to the direction of flow. To open turn the handle so that it lies parallel to the direction of flow.

## 3.3 COLD WATER COMBINATION VALVE (see Figure 2)

The Cold Water Combination Valve can be connected anywhere on the cold water mains supply prior to the Megaflo unit. There is no requirement to site it close to the unit, it can be located at a point where the mains supply enters the premises if this is more convenient. The Expansion Valve connection must not be used for any other purpose.

The Cold Water Combination Valve can be installed as a complete one-piece unit. The valve incorporates a factory set, non-adjustable Pressure Reducer/Strainer, an Expansion Valve connection and a single Check Valve. The valve can be fitted in any orientation to suit the installation, however, ensure that the Valve is installed with the direction of flow arrows (stamped on the side of the brass body) pointing towards the Megaflo heater. Should you wish to site the Expansion Valve on the Cold Water Combination Valve this can be done by unscrewing the connection nut beneath the Expansion Valve on the Expansion Core Unit and removing the Expansion Valve. The connecting nut and blanking plug should then be unscrewed from the Cold Water Combination Valve and replaced with the Expansion Valve.

**Note: if the Expansion Valve is fitted to the Cold Water Combination Valve the Expansion Core Unit should not be used as the Check Valve within it will prevent free passage of expanded water to the Expansion Valve.** Ensure the discharge from the Expansion Valve can be correctly installed.

If a balanced pressure cold water supply is required to a thermostatic shower mixer valve this may be teed off the supply to the Megaflo immediately after the Cold Water Combination Valve (see Figure 4). **Branches to drinking water outlets should be taken before the valve to avoid the possibility of warm expanded water being drawn from the tap.**

## 3.4 EXPANSION CORE UNIT (see Figure 3)

Should a balanced pressure cold water supply be required for other cold water outlets the Expansion Core Unit supplied should be used. The Core Unit should be fitted into the pipework between the Cold Water Combination Valve and the Megaflo (note direction of flow

arrows). The cold water balanced draw off connection should be taken from between the Cold Water Combination Valve and the Expansion Core Unit (see Figure 5). The Expansion Valve connection on the Cold Water Combination Valve should remain blanked off using the blanking nut and seal provided. Ensure the discharge from the Expansion Valve can be correctly installed.

**Figure 2 - Cold Water Combination Valve**

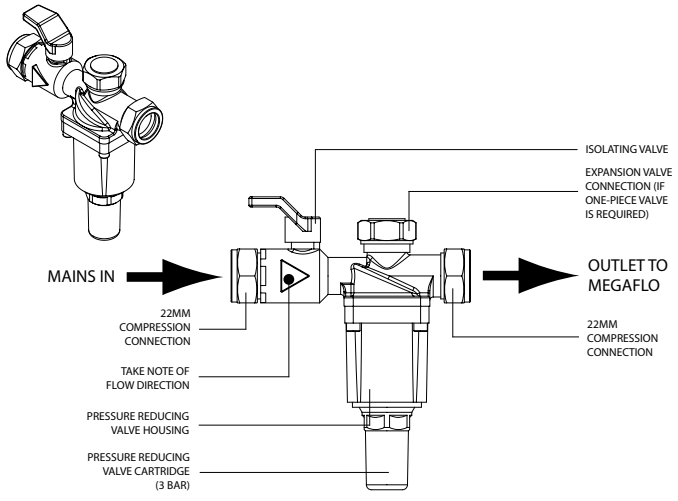

**Figure 3 - Expansion Core Unit**

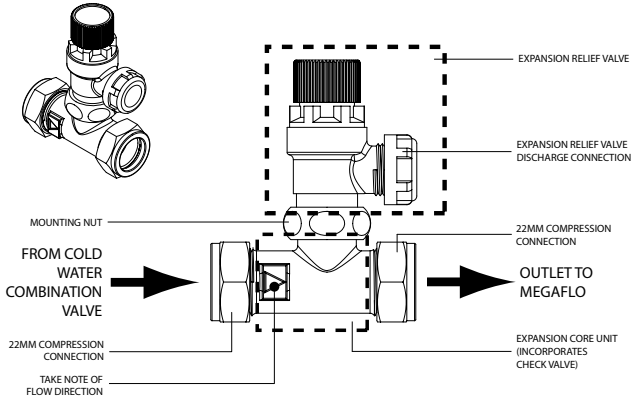
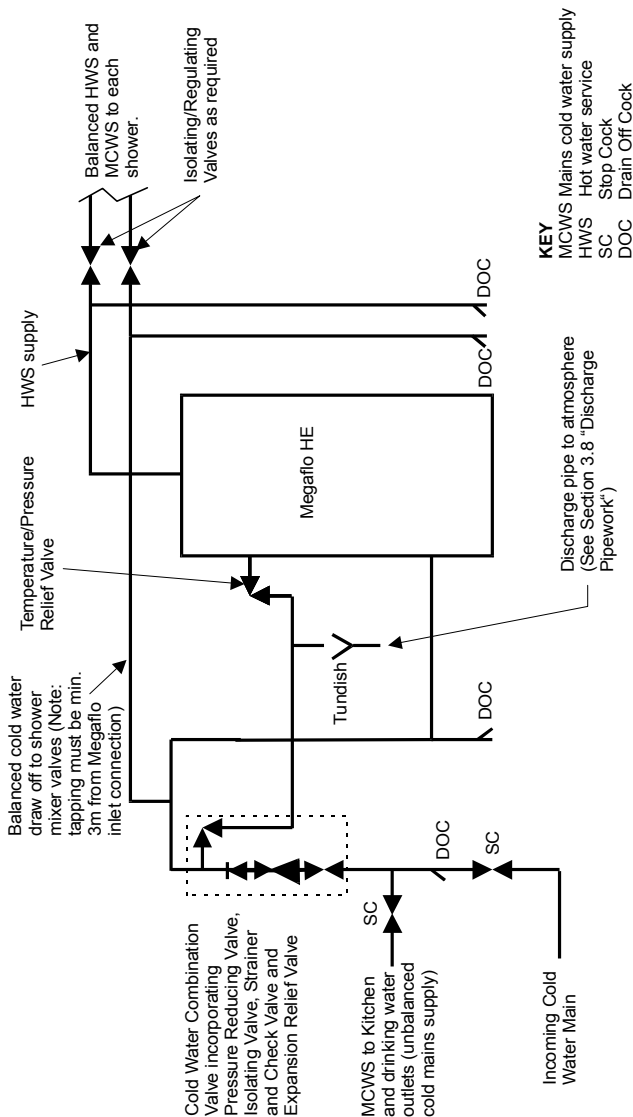
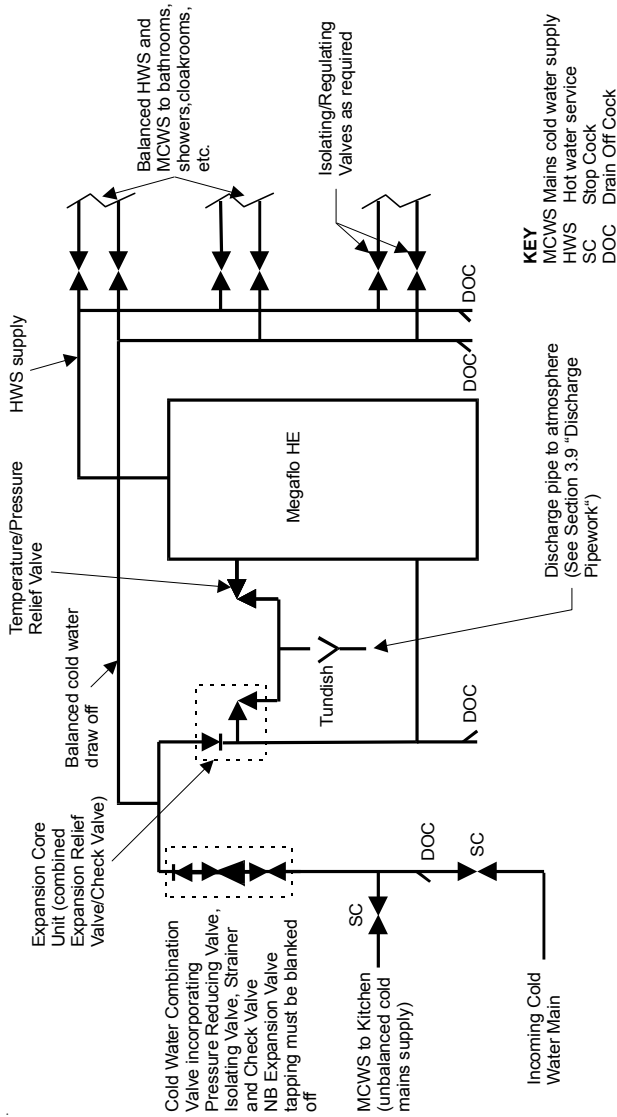

Figure 4 - Schematic installation diagram using Cold Water Combination Valve



**Figure 5 - Schematic installation diagram using Cold Water Combination Valve in conjunction with Expansion Core Unit**



**KEY**  
 MCWS Mains cold water supply  
 HWS Hot water service  
 SC Stop Cock  
 DOC Drain Off Cock

### 3.5 DRAIN TAP

A draining tap is supplied and should be installed in the cold water supply to the Megaflo unit between the Cold Water Combination Valve (or Expansion Core Unit if being used) and the heater at as low a level as possible (see Figure 1). It is recommended that the outlet point of the drain pipe work be at least 1 metre below the level of the heater (this can be achieved by attaching a hose pipe to the drain tap outlet spigot). The draining tap supplied provides very good water flow control and blanking cap for extra security.

### 3.6 OUTLET PIPEWORK

Ideally the pipework from the Megaflo to the outlet fittings should be in 22mm pipe with short runs of 15mm pipe to showers and basin taps. Small bore pipe can also be used to suit some taps, but runs should be of minimum length. Pipe sizes may vary due to system design.

### 3.7 SECONDARY CIRCULATION

If a secondary circulation system is required it is recommended that it be connected to the Megaflo as shown in Figure 6 via a Swept Tee joint (not supplied - available as an accessory, order code no. 95 970 509). The secondary return pipe should be in 15mm pipe and incorporate a check valve to prevent backflow. A suitable WRAS approved bronze circulation pump will be required. On large systems, due to the increase in system water content, it may be necessary to fit additional expansion volume to the system by fitting an external expansion vessel to the secondary circuit. This should be done if the capacity of the secondary circuit exceeds 10 litres.

Pipe capacities (copper)

15mm o/d = 0.13 litres per metre run (10 litres = 77m)

22mm o/d = 0.38 litres per metre run (10 litres = 26m)

28mm o/d = 0.55 litres per metre run (10 litres = 18m)

**Secondary circulation is NOT recommended for direct electric units being used on Off Peak electricity tariffs.**

### 3.8 T&P RELIEF VALVE INSULATION

A set of insulating components is supplied with the Megaflo water heater and should be installed to gain maximum heat and energy saving benefits. See Figure 7 for installation instructions.

### 3.9 WARNINGS

- i) **Under no circumstances should the factory fitted Temperature/Pressure Relief Valve be removed other than by Authorised Heatrae Sadia personnel. To do so will invalidate any guarantee or claim.**

- ii) The Cold Water Combination Valve must be fitted to the mains water supply to the MEGAflo unit.
- iii) No control or safety valves should be tampered with.
- iv) Water may drip from the discharge pipe of the pressure relief device (Expansion Valve) and this pipe must be left open to atmosphere. The discharge pipe should not be blocked or used for any other purpose.

**Figure 6 - Secondary circulation connection**

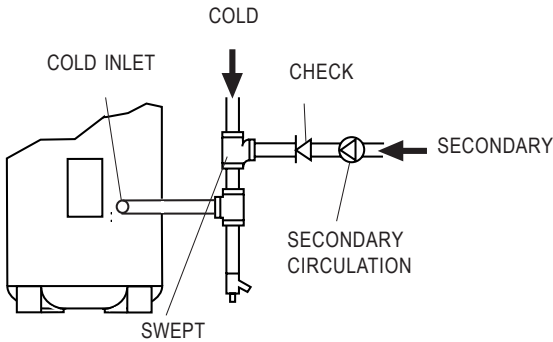

**Figure 7 - Installation of T&P insulation set**

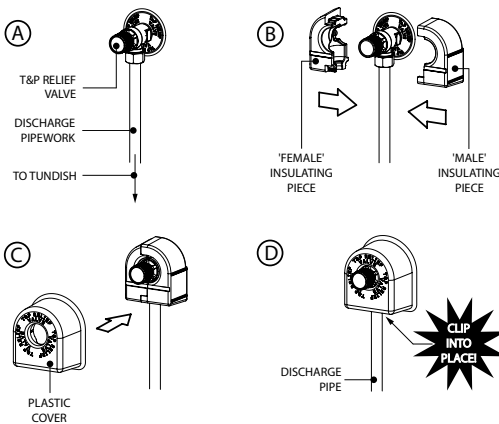

### 3.10 DISCHARGE PIPEWORK

It is a requirement of Building Regulations that any discharge from an unvented system is conveyed to where it is visible, but will not cause danger to persons in or about the building. The tundish and discharge pipes should be fitted in accordance with the requirements and guidance notes of Building Regulations. Building Regulation G3 Requirements and Guidance section 3.9 are reproduced in the following sections.

Information Sheet No. 33 available from the British Board of Agrément gives further advice on discharge pipe installation. For discharge pipe arrangements not covered by G3 Guidance or BBA Info Sheet No.33 advice should be sought from your local Building Control Officer.

Any discharge pipe connected to the pressure relief devices (Expansion Valve and Temperature/Pressure Relief Valve) must be installed in a continuously downward direction and in a frost free environment.

The water may drip from the discharge pipe of the pressure relief device and that this pipe must be left open to the atmosphere. The pressure relief device is to be operated regularly to remove lime deposits and to verify that it is not blocked.

#### G3 REQUIREMENT

"...there shall be precautions...to ensure that the hot water discharged from safety devices is safely conveyed to where it is visible but will not cause danger to persons in or about the building."

#### G3 GUIDANCE SECTION 3.9

The discharge pipe (D1) from the vessel up to and including the tundish is generally supplied by the manufacturer of the hot water storage system. Where otherwise, the installation should include the discharge pipe(s) (D1) from the safety device(s). In either case the tundish should be vertical, located in the same space as the unvented hot water storage system and be fitted as close as possible and within 500mm of the safety device e.g. the temperature relief valve.

The discharge pipe (D2) from the tundish should terminate in a safe place where there is no risk to persons in the vicinity of the discharge, preferably be of metal and:

a. be at least one pipe size larger than the nominal outlet size of the safety device unless its total equivalent hydraulic resistance exceeds that of a straight pipe 9m long i.e. discharge pipes between 9m and 18m equivalent resistance length should be at least two sizes larger than the nominal outlet size of the safety device, between 18 and 27m at least 3 sizes larger, and so on. Bends must be taken into account in calculating the flow resistance. Refer to Diagram 7, Table 1 and the worked example.

An alternative approach for sizing discharge pipes would be to follow BS 6700:1987 *Specification for design, installation, testing and maintenance of services supplying water for domestic use within buildings and their curtilages*, Appendix E, section E2 and table 21.

b. have a vertical section of pipe at least 300mm long below the tundish before any elbows or bends in the pipe work.

c. be installed with a continuous fall, and in a frost free environment.

d. have discharges visible at both the tundish and the final point of discharge, but where this is not possible or is practically difficult there should be clear visibility at one or other of these locations.

Examples of acceptable discharge arrangements are:

- i. ideally below a fixed grating and above the water seal in a trapped gully.
- ii. downward discharges at low level; i.e. up to 100mm above external surfaces such as car parks, hard standings, grassed areas etc. are acceptable providing that where children may play or otherwise come into contact with discharges a wire cage or similar guard is positioned to prevent contact, whilst maintaining visibility.
- iii. discharges at high level; e.g. into a metal hopper and metal down pipe with the end of the discharge pipe clearly visible (tundish visible or not) or onto a roof capable of withstanding high temperature discharges of water and 3m from any plastics guttering system that would collect such discharges (tundish visible).
- iv. where a single pipe serves a number of discharges, such as in blocks of flats, the number served should be limited to not more than 6 systems so that any installation discharging can be traced reasonably easily. The single common discharge pipe should be at least one pipe size larger than the largest individual discharge pipe (D2) to be connected. If unvented hot water storage systems are installed where discharges from safety devices may not be apparent i.e. in dwellings occupied by blind, infirm or disabled people, consideration should be given to the installation of an electronically operated device to warn when discharge takes place.

**Note:** The discharge will consist of scalding water and steam. Asphalt, roofing felt and non-metallic rainwater goods may be damaged by such discharges.

#### Worked example of discharge pipe sizing

The example below is for a G1/2 temperature relief valve with a discharge pipe (D2) having 4 No. elbows and length of 7m from the tundish to the point of discharge.

From Table 1:

Maximum resistance allowed for a straight length of 22mm copper discharge pipe (D2) from a G1/2 temperature relief valve is 9.0m.

Subtract the resistance for 4 No. 22mm elbows at 0.8m each = 3.2m

Therefore the permitted length equates to: 5.8m

5.8m is less than the actual length of 7m therefore calculate the next largest size.

Maximum resistance allowed for a straight length of 28mm pipe (D2) from a G1/2 temperature relief valve equates to 18m.

Subtract the resistance of 4 No. 28mm elbows at 1.0m each = 4.0m

Therefore the maximum permitted length equates to: 14m

As the actual length is 7m, a 28mm (D2) copper pipe will be satisfactory.

Table 1 - Sizing of copper discharge pipe (D2) for common T&P relief valve sizes

Valve outlet size	Minimum size of discharge pipe D1	Minimum size of discharge pipe D2 from tundish	Maximum resistance allowed, expressed as a length of straight pipe (i.e. no elbows or bends)	Resistance created by each elbow or bend
G1/2	15mm	22mm	up to 9m	0.8m
		28mm	up to 18m	1.0m
		35mm	up to 27m	1.4m
G3/4	22mm	28mm	up to 9m	1.0m
		35mm	up to 18m	1.4m
		42mm	up to 27m	1.7m
G1	28mm	35mm	up to 9m	1.4m
		42mm	up to 18m	1.7m
		54mm	up to 27m	2.3m

Figure 8 - Schematic discharge pipe arrangement

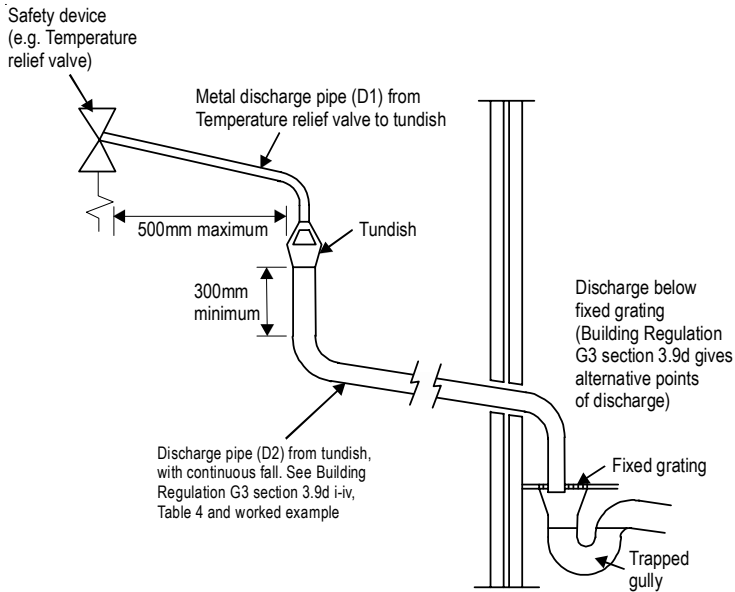

## 4 Installation - Direct units

### 4.1 IMMERSION HEATER(S)

The Megaflo is supplied with either one (D models), two (DD models) or three (DDD models) factory fitted immersion heaters. Each immersion heater is rated 3kW at 240V.

The DDD models are supplied with three immersion heaters and a blanking plug fitted to the uppermost of the three lower immersion heater bosses. Should a different combination be required the blanking plug and the upper (boost) immersion heater can be swapped.

To remove the blanking plug:

Ensure the cylinder is drained of water first. Open the cover to the uppermost of the three lower immersion heater bosses. The cover is secured by a cross-headed screw. Unscrew brass backnut using the key spanner provided with the unit. Remove the blanking plate and sealing gasket from the boss.

To remove the immersion heater:

Open the cover to the upper immersion heater. Unplug the thermostat from the element by gently pulling the thermostat outwards. Unscrew the brass backnut using the key spanner provided. Remove the immersion heater assembly and sealing gasket from the boss.

Replacement:

Insert the immersion heater and sealing gasket into the required boss. Ensure that the sealing gasket is not displaced when inserting. It may be helpful to support the immersion heater using a round bladed screwdriver inserted into one of the thermostat pockets. Hand tighten the brass backnut. Secure the immersion heater in position by tightening with the key spanner provided. Insert the blanking plate into the remaining boss ensuring the sealing gasket is not displaced when inserting. Hand tighten the brass backnut. Secure in position by tightening with the key spanner provided.

If an additional immersion heater is required order part no. 95 970 510.

### 4.2 WIRING (see Figure 8)

All electrical wiring should be carried out by a competent electrician and be in accordance with the latest I.E.E. Wiring Regulations. **Each circuit must be protected by a suitable fuse and double pole isolating switch with a contact separation of at least 3mm in both poles.**

The immersion heater(s) should be wired in accordance with Diagram 9. The immersion heaters **MUST** be earthed. The supply cable should be 1.5mm<sup>2</sup> 3 core HOFr sheathed and must be routed through the cable gland provided with the outer sheath of the cable firmly secured by tightening the screw on the cable gland. Replace the immersion heater cover(s) before operating ensuring that the threaded edge clip is in position to provide a suitable thread for the cover screw.

**DO NOT OPERATE THE IMMERSION HEATER(S) UNTIL THE MEGAFLO HAS BEEN FILLED WITH WATER.**

### 4.3 OPERATION

It is recommended that the immersion heater thermostats are set to between position 4 and 5 (60° - 65°C), however they can be set between 1 and 5 (10° and 70°C). The thermostat incorporates a thermal cut-out that will switch off the immersion heater in the event of a thermostat failure. The thermal cut-out reset button position is indicated on Figure 10. **DO NOT** bypass the thermal cut-out in any circumstances.

### 4.4 SAFETY

**DO NOT BYPASS THE THERMAL CUT-OUT(S) IN ANY CIRCUMSTANCES**

**DISCONNECT FROM THE MAINS SUPPLY BEFORE REMOVING ANY COVERS**

**NEVER ATTEMPT TO REPLACE AN IMMERSION HEATER OTHER THAN WITH THE RECOMMENDED HEATRAE SADIA MEGAFLO SPARE PART**

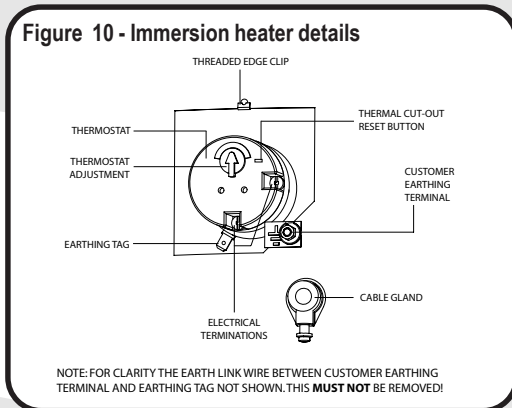
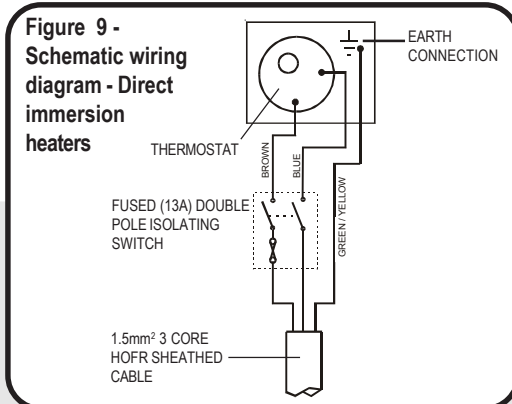

# Installation - Indirect units

## 5.1 BOILER SELECTION

The Megaflo Indirect (CL) models are suitable for use with most gas or oil fired boilers compatible with unvented systems i.e. fitted with a temperature control thermostat and thermal cut-out.

If in doubt consult the boiler manufacturer.

Solid fuel boilers or any other boiler in which the energy input is not under effective thermostatic control, unless additional and appropriate safety measures are installed, should NOT be used.

The boiler used can either be a sealed system or open vented type, maximum primary circuit pressure 3 bar.

The primary flow from the boiler MUST be pumped. Gravity circulation will not work due to the special design of the primary heat exchanger. It is recommended that an air bleed point or automatic air vent is incorporated in the primary return pipework close to the Megaflo unit.

The boiler flow temperature should usually be set to 82°C (maximum flow temperature to primary heat exchanger 90°C).

The boiler cannot be vented through the Megaflo unit.

## 5.2 INDIRECT THERMAL CUT-OUT AND 2-PORT MOTORISED VALVE

To comply with Building Regulations and to prevent the Megaflo from overheating the 2-port motorised valve supplied MUST be fitted to the primary flow to the indirect coil (see Figure 11).

## 5.3 WIRING

All electrical wiring should be carried out by a competent electrician and be in accordance with the latest I.E.E. Wiring Regulations.

The Megaflo Indirect Thermostat and Thermal Cut-Out are factory pre-wired. The 2-port motorised valve supplied MUST be wired in series with the Indirect controls such that the power supply to the valve is interrupted should either the Thermostat or Thermal Cut-Out operate. The Figures 13 or 14 detail the wiring required between these controls and the motorised valve. Wiring to external controls is made via the terminal block fitted. The cable should be routed through the aperture in the terminal cover and secured using the cable grip provided. **The Indirect Thermal Cut-out MUST NOT be bypassed.**

## 5.4 HEATING SYSTEM CONTROLS

The controls provided with the Megaflo will ensure the safe operation of the Megaflo within a central heating system. Other controls will be necessary to control the space heating requirements and times that the system is required to function. Depending on the boiler selected, heating circuit design and controls used it may be beneficial to incorporate a system bypass in the heating system pipework.

The Megaflo is compatible with most heating controls, examples of electrical circuits are given in Diagrams 13 and 14. However, other systems may be suitable, **refer to the controls manufacturers' instructions, supplied with the controls selected, for alternative system wiring schemes.**

## 5.5 IMMERSION HEATER(S)

The Megaflo indirect units (CL models) are supplied with an immersion heater which can be used as an alternative heat source should the boiler supply need to be isolated from the Megaflo unit. The immersion heater is located within the controls housing. Refer to Sections 4.2 and 4.3 and Diagram 9 for details of wiring and operation of the immersion heater. 210 litre models and above are supplied with a second blanked off boss which can be used for the connection of a second immersion heater should this be required.

To remove the blanking plug:

Ensure the cylinder is drained of water first. Open the cover to the upper immersion heater boss. Unscrew the brass backnut using the key spanner provided with the unit. Remove the blanking plate and sealing gasket from the boss.

Fitting additional immersion heater:

Insert the immersion heater and sealing gasket into the upper boss. Ensure that the sealing gasket is not displaced when inserting. It may be helpful to support the immersion heater using a round bladed screwdriver inserted into one of the thermostat pockets. Hand tighten the brass backnut. Secure the immersion heater in position by tightening with the key spanner provided.

If an additional immersion heater and thermostat assembly is required order part no. 95 970 510.

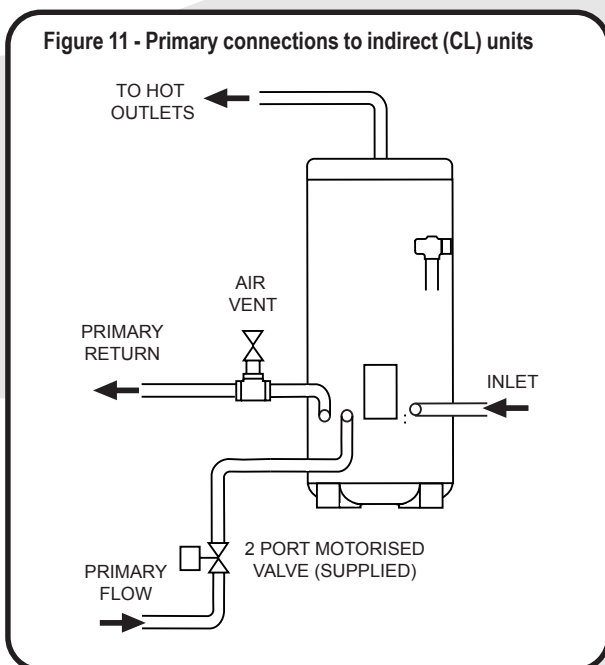
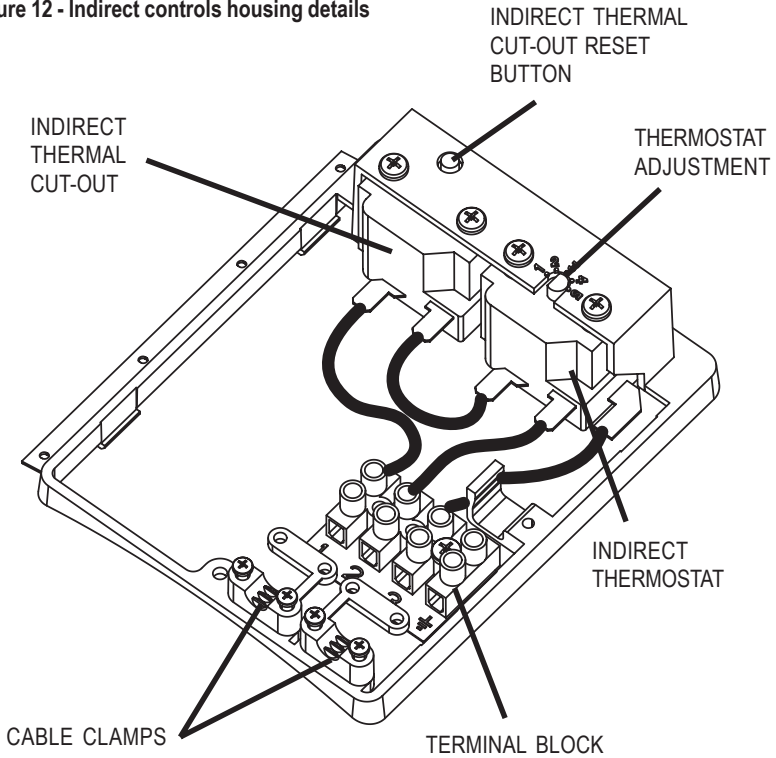
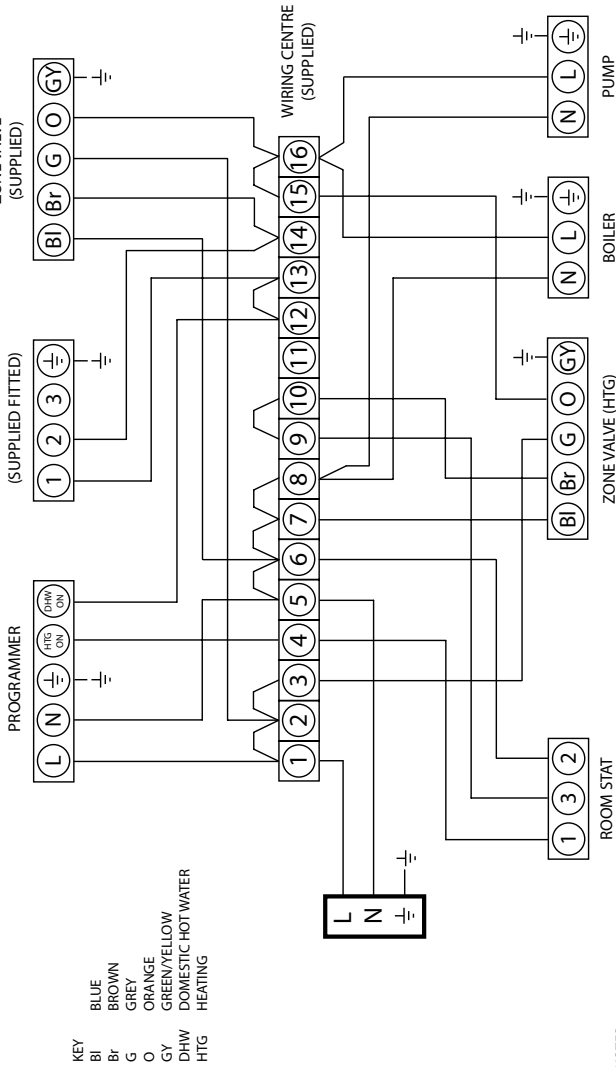

Figure 12 - Indirect controls housing details



NOTE:  
THE HOUSING COVER AND ELEMENT ASSEMBLY HAVE BEEN REMOVED  
FROM THIS VIEW FOR CLARITY

**Figure 13 - 2 x 2 port valve system**



- NOTES:**
1. A DOUBLE POLE ISOLATING SWITCH MUST BE INSTALLED IN THE MAINS SUPPLY.
  2. ALL EARTH CONNECTIONS MUST BE LINKED BACK TO THE MAINS EARTH SUPPLY.
  3. USE COPPER LINKS SUPPLIED TO MAKE CONNECTIONS BETWEEN TERMINALS.
  4. DO NOT MOUNT WIRING CENTRE ON CYLINDER
  5. THE ABOVE DIAGRAM IS FOR GUIDANCE ONLY. HEATRAE SADIA ACCEPT NO LIABILITY FOR ANY LOSS OR DAMAGE ARISING FROM ANY ERRORS OR OMISSIONS THAT MAY BE INADVERTENTLY CONTAINED WITHIN THIS DIAGRAM. THE VARIOUS EQUIPMENT MANUFACTURERS SHOULD BE CONSULTED TO CONFIRM THE CORRECT OPERATION OF THEIR PRODUCTS WITHIN THE SYSTEM.

**Figure 14 - MEGAflo 2 port valve in conjunction with a 3 port mid-position valve system**

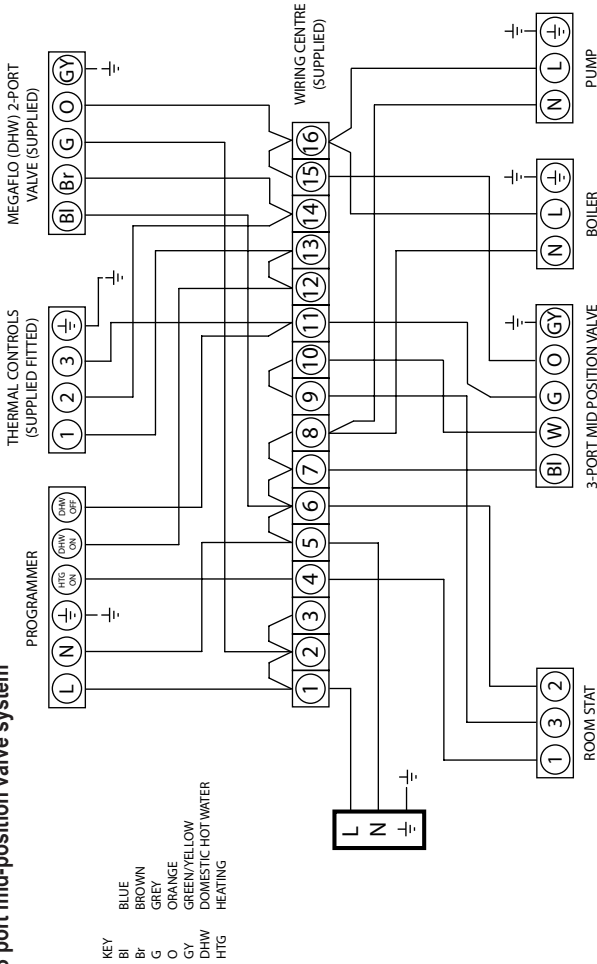

- NOTES:**
1. A DOUBLE POLE ISOLATING SWITCH MUST BE INSTALLED IN THE MAINS SUPPLY.
  2. ALL EARTH CONNECTIONS MUST BE LINKED BACK TO THE MAINS EARTH SUPPLY.
  3. ASSUMES BASIC BOILER WITH EXTERNAL PUMP.
  4. USE COPPER LINKS SUPPLIED TO MAKE CONNECTIONS BETWEEN TERMINALS.
  5. DO NOT MOUNT WIRING CENTRE ON CYLINDER.
  6. THE ABOVE DIAGRAM IS FOR GUIDANCE ONLY. HEATRAE SADIA ACCEPTS NO LIABILITY FOR ANY LOSS OR DAMAGE ARISING FROM ANY ERRORS OR OMISSIONS THAT MAY BE INADVERTENTLY CONTAINED WITHIN THIS DIAGRAM. THE VARIOUS EQUIPMENT MANUFACTURERS SHOULD BE CONSULTED TO CONFIRM THE CORRECT OPERATION OF THEIR PRODUCTS WITHIN THE SYSTEM.

## Commissioning

### 6.1 FILLING AND FLUSHING THE MEGAFLO

Ensure that all fittings and immersion heaters are correctly fitted and tightened. An immersion heater key spanner is provided to aid in tightening the immersion heater(s).

- i) Open a hot tap furthest from the Megaflo.
- ii) Open the isolating valve on the Cold Water Combination Valve by turning the black handle so that it lies parallel to the direction of flow. Open the mains stop cock to fill the unit. When water issues from the tap, allow to run for a few minutes to thoroughly flush through any residue, dirt or swarf, then close tap.
- iii) Open successive hot taps to purge any air from the system.
- iv) Check all connections for leaks and rectify as necessary.
- v) The Strainer housed within the Cold Water Combination Valve should be cleaned to remove any debris that may have been flushed through the main supply pipe. Refer to Section 8.3 for instructions on how to do this.

### 6.2 CHECK THE OPERATION OF THE SAFETY VALVES

- i) Slowly manually open, for a few seconds, the Temperature and Pressure Relief Valve situated on the Megaflo unit (see Figure 15). Check water discharged runs freely away through the tundish and discharge pipework. Close valve, ensure water flow stops and valve reseats correctly.
- ii) Repeat for the Expansion Valve situated on the Cold Water Combination Valve or Expansion Core Unit (see Figures 2 and 3).

### 6.3 DIRECT UNITS

Switch on the electrical supply to the immersion heater(s) and allow the unit to heat up. Check that the thermostat operates correctly. A storage temperature of approx. 60°C is recommended (between graduations 4 and 5 on the thermostat). If necessary the temperature can be adjusted by inserting a flat bladed screwdriver in the adjustment knob on top of the immersion heater thermostat and rotating (see Figure 10). The adjustment range 1 to 5 represents a temperature range of between 10° and 70°C.

Check that no water is discharged from either the Expansion Valve or Temperature and Pressure Relief Valve during the heating cycle.

### 6.4 INDIRECT UNITS

Fill the indirect (primary) circuit following the boiler manufacturer's commissioning instructions. To ensure the primary heating coil in the Megaflo is filled the 2-port motorised valve (supplied) should be manually opened by moving the lever on the motor housing to the MAN OPEN setting. When the primary circuit is full return the lever to the AUTO position. Vent any trapped air by opening the air bleed.

Switch on the boiler, ensure the programmer is set to Domestic Hot Water. Allow the Megaflo unit to heat up and check that the indirect thermostat and 2-port motorised valve operate correctly. A storage temperature of approx. 60°C is recommended (approx. graduation 4 on the indirect thermostat). If necessary the temperature can be adjusted by inserting a flat bladed screwdriver in the adjustment knob (located on the front of the thermostat mounting bracket see Figure 12) and rotating. The minimum thermostat setting is 10°C. The adjustment range 1 to 5 represents a temperature range of 30° to 70°C.

Check that no water is discharged from either the Expansion Valve or Temperature and Pressure Relief Valve during the heating cycle.

### 6.5 BENCHMARK™ LOG BOOK

On completion of the installation and commissioning procedures detailed in this manual the Benchmark™ “Installation, Commissioning and Service Record Log Book” should be completed and signed off by the competent installer or commissioning engineer in the relevant sections.

The various system features, location of system controls, user instructions and what to do in the event of a system failure should be explained to the customer. The customer should then countersign the Benchmark™ log book to accept completion.

The log book should be left with the customer along with these instructions. The log book includes sections that should be filled in when any subsequent service or maintenance operation is carried out on the Megaflo.

# User Instructions

## 7.1 WARNINGS

IF WATER ISSUES FROM THE TEMPERATURE/PRESSURE RELIEF VALVE ON THE MEGAFLO UNIT REFER TO SECTION 7.4 FIRST. IF THIS DOES NOT RECTIFY THE FAULT SWITCH OFF ELECTRICAL SUPPLY TO THE IMMERSION HEATER(S) (DIRECT UNITS) OR SHUT DOWN THE BOILER (INDIRECT UNITS). DO NOT TURN OFF THE WATER SUPPLY. CONTACT A COMPETENT INSTALLER FOR UNVENTED WATER HEATERS TO CHECK THE SYSTEM.

DO NOT TAMPER WITH ANY OF THE SAFETY VALVES FITTED TO THE MEGAFLO SYSTEM, IF A FAULT IS SUSPECTED CONTACT A COMPETENT INSTALLER.

## 7.2 TEMPERATURE CONTROL

### IMMERSION HEATERS

A combined thermostat and thermal cut-out is provided for each immersion heater. The thermostat is factory set to give a water storage temperature of approx. 60°C, however it can be set to control between 10°C and 70°C. This will usually have been done during installation. Adjustments can only be made by opening the terminal cover(s), **DO NOT remove the cover(s) without first switching off the electrical supply**. The temperature adjustment is made by inserting a flat bladed screwdriver in the slot in the disc on top of the thermostat and rotating (see Figure 10).

If in any doubt consult a competent electrician.

### INDIRECT UNITS

Indirect units (CL models) are fitted with an Indirect Thermostat which controls a 2-port motorised valve and hence the temperature of the water in the MegaFlo unit. The thermostat is factory set to give a water storage temperature of approx. 60°C, however it can be set to control between 10°C and 70°C, this will usually have been done during installation. Adjustments can only be made by opening the terminal cover. **DO NOT remove the cover without first switching off the electrical supply**. Temperature adjustment is made by inserting a flat bladed screwdriver in the adjustment knob located on the front of the thermostat mounting bracket (see Figure 12) and rotating. At the minimum position the temperature will be approx. 10°C. The adjustment range 1 to 5 represents a temperature range of 30° to 70°C

If in any doubt consult a competent electrician.

**DO NOT bypass the thermal cut-out in any circumstances.**

## 7.3 FLOW PERFORMANCE

When initially opening hot outlets a small surge in flow may be noticed as pressures stabilise. This is quite normal with unvented systems and does not indicate a fault.

In some areas a cloudiness may be noticed in the hot water. This is due to aeration of the water, is quite normal and will quickly clear.

#### 7.4 OPERATIONAL FAULTS

Operational faults and their possible causes are detailed in Section 9.3. It is recommended that faults should be checked by a competent installer.

The air volume within the Megaflo unit will periodically require recharging to ensure any expanded water is accommodated within the unit. A discharge of water INTERMITTENTLY from the Expansion Relief Valve will indicate the air volume has reduced to a point where it can no longer accommodate the expansion. To recharge the air volume :-

- i) Turn off the heat source to the cylinder via programmers/immersion isolation switch(es).
- ii) Turn off the water supply to the Megaflo unit by turning off the isolating valve on the Cold Water Combination Valve. Turn the black handle so that it lies at 90° to the direction of flow.
- iii) Open the lowest hot tap supplied by the Megaflo.
- iv) Hold open the Temperature/Pressure Relief Valve until water ceases to run from the tap and gurgling noise at the valve stops.
- v) Close Temperature/Pressure Relief Valve.
- vi) Turn on the isolating valve at the Cold Water Combination Valve by turning the black handle so it lies parallel to the direction of flow, when water flows from the hot tap, close tap.
- vi) The air volume will be automatically recharged as the unit refills.

If after following the above actions water still discharges from the Expansion Relief Valve further advice should be sought from a competent installer or the Heatrae Sadia Service Department.

## Maintenance

### 8.1 MAINTENANCE REQUIREMENTS

To ensure the continued optimum performance of the Megaflo it should be regularly maintained. This is of particular importance in hard water areas or where the water supply contains particulate matter. Maintenance should be carried out by a competent person and any replacement parts used should be authorised Heatrae Sadia Megaflo spare parts. It is recommended that maintenance is carried out every 12 months and includes the checks detailed in 8.2 and 8.3 below.

In hard water areas consideration should be given to periodically descaling the immersion heater elements. To do this the Megaflo unit will need to be drained, 8.4 and 8.5 below detail how to drain the unit and remove the immersion heater(s).

### 8.2 CHECK OPERATION OF SAFETY VALVES

Slowly open the Temperature and Pressure Relief Valve by twisting its cap for a few seconds. Check water is discharged and that it flows freely through the tundish and discharge pipework. Check valve reseats correctly when released.

**NOTE : The water discharged may be very hot.**

Repeat the procedure for the Expansion Relief Valve (located on the Cold Water Combination Valve or Expansion Valve Core Unit).

### 8.3 CLEAN THE STRAINER

The strainer is incorporated within the Pressure Reducing Valve housing of the Cold Water Combination Valve (see Figure 2). To inspect and clean the strainer:

- i) Turn off the isolating valve on the Cold Water Combination Valve by turning the black handle so it lies 90° to the direction of flow.
- ii) Open the lowest hot tap in the system to relieve the system pressure.
- iii) Using a spanner unscrew the pressure reducing cartridge and remove the moulded housing. The strainer will be removed with the cartridge.
- iv) Wash any particulate matter from the strainer under clean running water.
- v) Replace the strainer and screw the Pressure Reducing Valve cartridge into the moulded housing.
- vi) Close hot tap, turn on isolating valve by turning handle so it lies parallel to the direction of flow. Check for leaks.

### 8.4 DRAINING THE MEGAFLO UNIT

**Switch off the electrical supply to the immersion heater(s) and shut down the boiler on indirect units.** Turn off the mains water supply to the Megaflo unit. Attach a hosepipe to the drain cock having sufficient length to take water to a suitable discharge point below the level of the unit, at least one metre below the unit is recommended. Open hot water tap nearest to the Megaflo to relieve the system pressure. Open drain cock. If water fails to drain from the Megaflo vent the unit by manually opening the Temperature/Pressure Relief Valve.

### 8.5 DESCALING IMMERSION HEATER(S)

Open the cover(s) to the immersion heater housing(s) and disconnect wiring from immersion heater(s). Remove the thermostat by carefully pulling outwards from the immersion heater. Unscrew immersion heater backnut(s) and remove immersion heater from the unit. A key spanner is supplied with the MegaFlo unit for easy removal/tightening of the immersion heater(s). Over time the immersion heater gasket may become stuck to the mating surface. To break the seal insert a round bladed screwdriver into one of the pockets on the immersion heater and gently lever up and down.

Carefully remove any scale from the surface of the element(s). DO NOT use a sharp implement as damage to the element surface could be caused. Ensure sealing surfaces are clean and seals are undamaged, if in doubt fit a new gasket.

Replace immersion heater(s) ensuring the lower (right angled) element hangs vertically downwards towards the base of the unit. It may be helpful to support the immersion heater using a round bladed screwdriver inserted into one of the thermostat pockets whilst the backnut is tightened. Replace the thermostat(s) by carefully plugging the two male spade terminations on the underside of the thermostat head into the corresponding terminations on the element.

Rewire the immersion heater(s) in accordance with Figure 9. Close and secure terminal cover(s).

### 8.6 REFILLING SYSTEM

**DO NOT** switch on the immersion heater(s) or boiler until the system has been completely refilled.

Close the drain tap. With the hot tap open, turn on mains water supply. When water flows from the hot tap allow to flow for a short while to purge air and to flush through any disturbed particles. Close hot tap and then open successive hot taps in system to purge any air. The electrical supply can now be switched on.

### 8.7 BENCHMARK™ LOG BOOK

On completion of any maintenance or service of the MegaFlo, the Benchmark™ "Installation, Commissioning and Service Record Log Book" should be filled in to record the actions taken and the date the work was undertaken.

## Fault Finding & Servicing

### 9.1 IMPORTANT

- i) Servicing should only be carried by authorised Heatrae Sadia Service Engineers or Agents or by installers competent in the installation and maintenance of unvented water heating systems.
- ii) Any spare parts used **MUST** be authorised Heatrae Sadia parts.
- iii) **Disconnect** the electrical supply before removing any electrical equipment covers.
- iv) **NEVER** bypass any thermal controls or operate system without the necessary safety valves.
- v) Water contained in the Megaflo unit may be very hot, especially following a thermal control failure. Caution must be taken when drawing water from the unit.

### 9.2 SPARE PARTS

A full range of spare parts are available for the Megaflo range. Refer to the Technical Data label on the unit to identify the model installed and ensure the correct part is ordered.

Description	Part no.
Immersion heater (lower)	95 606 963
Immersion heater (upper)	95 606 964
Immersion heater gasket	95 611 822
Immersion heater backnut	95 607 869
Immersion heater key	95 607 861
Immersion heater blanking plug	95 605 881
Tundish	95 605 838
Expansion relief valve cartridge - 8bar	95 605 870
Expansion valve complete	95 607 028
Cold water combination valve body incl. isolating valve	95 605 029
Check valve housing	95 605 028
Pressure reducing valve cartridge - 3bar	95 605 026
Pressure reducing valve housing	95 605 027
Cold water combination valve complete	95 605 021
Temperature/pressure relief valve	95 605 810
Expansion core unit	95 605 041
Swept tee	95 605 812
Set of compression nuts and olives	95 607 838
Drain valve	95 605 051
Insulation set (T&P relief valve)	95 607 089
<b>Direct units only:</b>	
Combined thermostat/thermal cut-out	95 612 026
Terminal cover	95 607 836
Accessory kit (direct)	95 607 090
<b>Indirect (CL) units only:</b>	
2-port motorised valve	95 605 819
Indirect thermostat	95 612 697
Indirect thermal cut-out	95 612 698
Terminal cover	95 607 837
4 way terminal block	95 607 902
Wiring centre	95 607 008
Accessory kit (indirect)	95 607 091

**Figure 15 - Exploded view of the Cold Water Combination Valve and Expansion Core Unit**

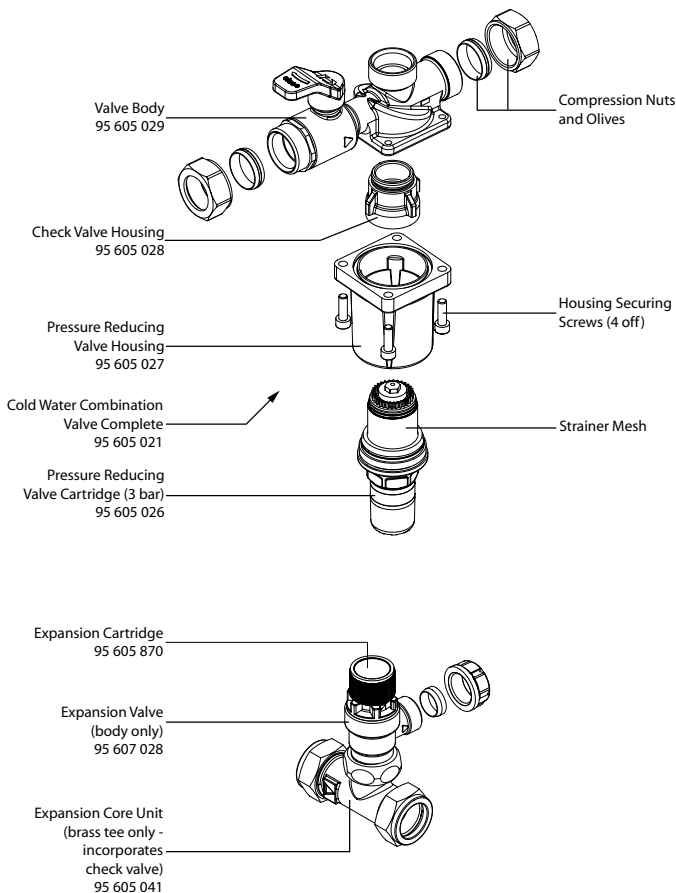

### 9.3 FAULT FINDING

The Fault Finding chart overleaf (Table 2) will enable operational faults to be identified and their possible causes rectified. Any work carried out on the Megaflo unvented water heater and its associated controls **MUST** be carried out by a competent installer for unvented water heating systems. In case of doubt contact the Heatrae Sadia Service Department (see Section 12).

**Table 2 - Fault Finding Chart**

FAULT	POSSIBLE CAUSE	REMEDY
No hot water flow	1. Mains supply off	1. Check and open stop cock
	2. Strainer blocked	2. Turn off water supply. Remove strainer and clean (see section 8.3)
	3. Cold water combination valve incorrectly fitted	3. Check and refit as required
Water from hot taps is cold	1. DIRECT immersion heater heater not switched on	1. Check and switch on
	2. DIRECT immersion heater thermal cut-out has operated	2. Check. Reset by pushing button (see Fig 10)
	3. INDIRECT programmer set to central heating only	3. Check. Set to a Domestic Hot Water programme
	4. INDIRECT boiler not work	4. Check boiler operation. If fault is suspected consult boiler manufacturer's instructions
	5. INDIRECT thermal cut-out has operated	5. Check. Reset by pushing button on cut-out. Check operation of indirect thermostat (see Fig 12)
	6. INDIRECT motorised valve not connected correctly	6. Check wiring and/or plumbing connections to motorised valve (see Figs 13 & 14)
Water discharges from Expansion Relief Valve	1. INTERMITTENTLY Expansion volume has reduced within unit	1. See section 7.4 for re-charging procedure
	2. CONTINUALLY Cold Water Combination Valve Pressure Reducer not working properly	2. Check pressure from Cold Water Combination Valve. If greater than 3 bar replace Pressure Reducing Cartridge
	3. CONTINUALLY Expansion Valve seat damaged	3. Remove Expansion Valve Cartridge. Check condition of seat. If necessary fit new Expansion Valve Cartridge
Water discharges from T&P Relief Valve	1. Thermal Control failure NOTE water will be very hot!	1. Switch off power to immersion heater(s) and shut down boiler. DO NOT turn off water supply. When discharge stops check all thermal controls, replace if faulty
Milky water	1. Oxygenated water	1. Water from a pressurised system releases oxygen bubbles when flowing. The milkiness will disappear after a short while

# Dimensions & Specifications

Figure 16 - Dimensions

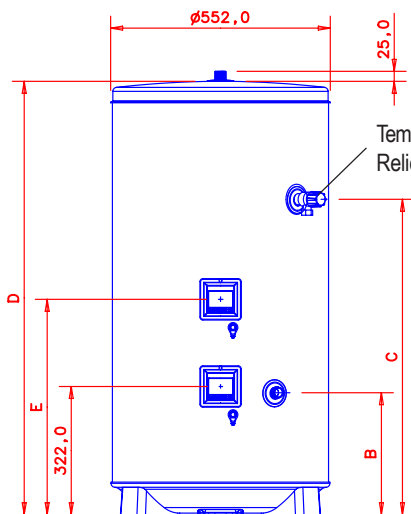

Direct units

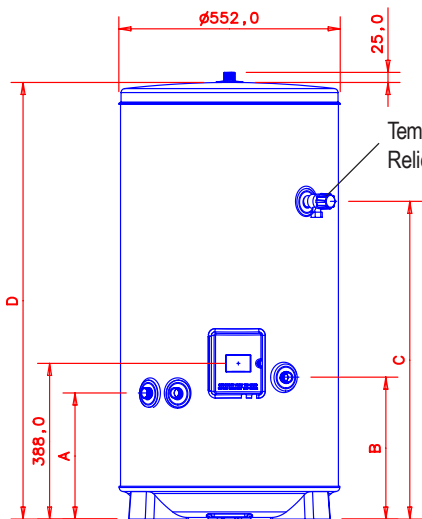
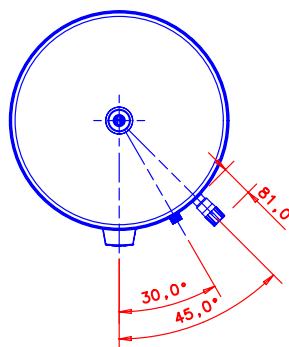

Indirect units

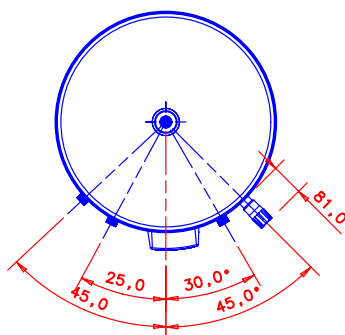

**Table 3 - Dimensions**

SIZE	TYPE		DIMENSIONS (mm)				
	DIRECT	INDIRECT	A	B	C	D	E
70	D		N/A	308	494	784	N/A
70		CL	315	354	494	784	N/A
125	D		N/A	308	793	1090	541
125		CL	315	354	793	1090	N/A
145	D		N/A	308	894	1215	642
145		CL	315	354	894	1215	N/A
170	D		N/A	308	1019	1372	767
170		CL	315	354	1019	1372	N/A
210	D		N/A	308	1095	1474	861
210		CL	315	354	1095	1474	N/A
250	D		N/A	308	1322	1726	1071
250		CL	315	354	1322	1726	N/A
300	D		N/A	308	1573	2040	1375
300		CL	315	354	1573	2040	N/A

**Table 4 - Direct units - Technical specifications**

SIZE	UNIT WEIGHT (KG)		HEAT UP TIMES (MINS)			
	EMPTY	FULL	MODEL D (3KW)	MODEL DD (6KW)	MODEL DDD (9KW)	BOOST (3 KW)
70	23	123	87	N/A	N/A	N/A
125	25	174	137	69	N/A	66
145	31	200	153	77	N/A	72
170	34	228	181	91	N/A	79
210	38	248	199	100	67	85
250	45	295	238	119	79	92
300	55	355	287	144	96	97

**Table 5 - Indirect units - Technical specifications**

SIZE	UNIT WEIGHT (KG)		COIL SPECIFICATIONS			
	EMPTY	FULL	SURFACE (SQ.M)	HEAT UP (MINS)	RECOVERY (MINS)	RATING (KW)
70	25	125	0.61	17	10	15.4
125	27	176	0.61	23	15	18.3
145	35	204	0.73	24	17	18.7
170	38	233	0.79	22	16	24.3
210	43	254	0.79	28	19	24.3
250	50	301	0.79	34	23	23.9
300	60	360	0.79	39	27	24.5

**NOTE**

Coil heating performance based on a primary flow rate of 15 l/min at 80° C.  
Temperature rise is from 15° C to 60° C.

**OUTLINE SPECIFICATIONS**

<b>Maximum mains water supply pressure (to Cold Water Combination Valve)</b>	1.6 MPa (16 bar)
<b>Operating pressure (Pressure reducing valve set pressure - non adjustable)</b>	0.3 MPa (3 bar)
<b>Expansion relief valve set pressure</b>	0.8 MPa (8 bar)
<b>Temperature/Pressure relief valve set temp/pressure</b>	90°C/1MPa (10 bar)
<b>Immersion heater rating (a.c. supply only)</b>	3.0kW @ 240V 2.7kW @ 230V

**Outer casing:**

White textured plastic coated corrosion proofed steel

**Water container:**

Duplex stainless steel (grade 1.4362 to EN10088). 100% pressure tested to 1.5 MPa (15 bar).

**Thermal insulation:**

CFC/HCFC free fire retardant expanded polyurethane foam with zero ozone depletion potential. It has a Global Warming Potential (GWP) of 3.1. Nominal thickness 50mm.

**Pipe connections:**

All connections accept 22mm outside diameter pipe - compression nuts and olives supplied. Thread rate is 3/4" BSP male parallel to accept standard 3/4" BSP female fittings if required.

**Safety features:**

Direct units -

- Manually resettable thermal cut-out on each heating element
- Factory fitted Temperature/Pressure relief valve

Indirect units -

- Manually resettable thermal cut-out on heating element
- Manually resettable thermal cut-out for primary heating. Must be wired in conjunction with 2-port motorised valve supplied.
- Factory fitted Temperature/Pressure relief valve

## Guarantee

### 11.1 WARNING

Should the factory fitted Temperature and Pressure Relief Valve be tampered with or removed your guarantee will be invalidated. Neither the Distributor nor Manufacturer shall be responsible for any consequential damage howsoever caused.

### 11.2 GUARANTEE TERMS

Heatrae Sadia guarantee the electrical parts, thermal controls and valves for a period of two years, excluding the cold water control valve which is guaranteed for a period of five years, from the date of purchase, with the exception of damage due to scaling.

The stainless steel vessel is guaranteed for a period of twenty-five years against faulty manufacture or materials provided that :-

- i) It has been installed by a competent installer and as per the instructions contained in this manual and all relevant Codes of Practice and Regulations in force at the time of installation.
- ii) Any disinfection has been carried out in accordance with BS 6700.
- iii) It has not been modified in any way other than by Heatrae Sadia Heating.
- iv) It has only been used for the storage of wholesome water.
- v) It has not been installed in a location liable to be subjected to frost, nor has it been tampered with or been subjected to misuse or neglect.
- vi) No factory fitted parts have been removed for unauthorised repair or replacement.
- vii) Within 60 days of purchase the user completes and returns the certificate supplied to register the product.

Evidence of purchase and date of supply must be submitted.

This guarantee is not valid for installations outside the United Kingdom and the Republic of Ireland. For installations outside these territories please contact either the Heatrae Sadia Heating Export Department (Tel: +44 1603 420191) or Baxi International (Tel: + 44 1926 478323) for further details of the guarantee terms and conditions applicable.

This guarantee does not affect your statutory rights.

### ENVIRONMENTAL INFORMATION

This product is made from many recyclable materials, therefore at the end of its useful life it should be disposed of at a Local Authority Recycling Centre in order to realise the full environmental benefits.

Insulation is by means of an approved HCFC/CFC free polyurethane foam.

The pace of product development is such that we reserve the right to change product specifications without notice. We do, however, strive to ensure that all information in this leaflet is accurate at the time of publication

## Contacts

### CUSTOMER SERVICE

Tel: 0844 8711535  
Fax: 0844 8711528  
E-mail: [heatraesadiaservice@heateam.co.uk](mailto:heatraesadiaservice@heateam.co.uk)

### ADDRESS

Heatrae Sadia Heating  
Hurricane Way  
Norwich  
Norfolk  
NR6 6EA

### SWITCHBOARD

Tel: 01603 420100

### SPARES STOCKISTS

Electric Water Heating Co.  
2 Horsecroft Place, Pinnacles,  
Harlow, Essex  
CM19 5BT  
Tel: 0845 0553811  
E-mail: [sales@ewh.co.uk](mailto:sales@ewh.co.uk)

### SPD

Special Product Division  
Units 9 & 10  
Hexagon Business Centre  
Springfield Road  
Hayes  
Middlesex  
UB40 0TY  
Tel: 020 8606 3567

### Parts Center

Network 65 Business Park  
Bentley Wood Way  
Burnley, Lancashire  
BB11 5ST  
Tel: 01282 834403  
[www.partscenter.co.uk](http://www.partscenter.co.uk)

### Newey & Eyre

Specialist Products Division  
Please contact your local branch

### UK Spares Ltd.

Tower Lane, Warmley  
Bristol  
BS30 8XT  
Tel: 0117 961 6670

### William Wilson Ltd.

Unit 3A, 780 South Street,  
Whiteinch, Glasgow  
G14 0SY  
Tel: 0141 434 1530

A division of BAXI GROUP